

: anticipatory design

October 2016

3.36€



DTb

The Dukeries Thinkbelt is a seriously considered project for revitalizing that area of Western Nottinghamshire which has for generations depended for its livelihood and all sense of community on the extraction of coal. This industry is now declined. Anticipating such a turn of events (see below), Cedric Price's revolutionary proposal was that advanced education – and in particular advanced technical education – should become the new prime industry. But not education alone: local industries (old and new) would be encouraged to develop in close conjunction with university training and research programmes. Properly concentrated, the best equipment and teachers would be available to all. There would be no uneasy demarcation between manufacture and learning. They would be integrated. To ensure this, teaching would take place wherever the particular research and manufacture related to it is sited. Students would be constantly on the move from

Life-conditioning II

Cedric Price (ed. Norman Fellows)

A greater awareness in architects and planners of their real value to society could, at the present, result in that rare occurrence, namely, the improvement of the quality of life as a result of architectural endeavour.

Although basic behavioural patterning of institutions and individuals has been increasingly questioned over the last 50 years, the period of wholesale rejection of old mores, through expediency, necessity or intelligence, is comparatively recent. Such rejection has enabled a wide range of new, less well-defined or pedigree-shrouded, social, economic and administrative patterns to evolve. Thus the building of a new Colonial Office becomes a non-problem, while the days of pit-head baths are numbered. Far from encouraging such change and accelerating its ordered advance, architects and planners would appear to show no realization of its capacity to make such a contribution. In fact most architects and planners have consistently produced ammunition for the reactionaries.

(Civic centres, green belts, the rehabilitation of No.10 Downing Street, Coventry Cathedral, Brasilia and Piccadilly Circus Mark 3 do not strike me as particularly constructive solutions to their causatory discontents.)

I consider it unlikely that architecture and planning will match the contribution Hush Puppies have made to society today, let alone approach that of the transistor or loop until a total reappraisal of its particular expertise is self-imposed or inflicted from outside.

Unfortunately the nature of education of architects and planners is primarily directed at producing three-dimensional disciplining for all-comers. Perhaps this would not be so bad if any assessment were made of the valid life-span of the client's intentions and desires. (The well-meaning progressive parents/institutions who, on planning their future home with their architect/planner, are concerned about inbuilt flexibility that will enable their offsprings to live quite differently from them, tragically ignore the increasing possibility that their loved ones will not stay around to enjoy such consideration.)

Change and flexibility in architecture and planning is associated by the professions with the adaptation, extension, or most progressively with the limited life of

structures and organizations, which, however, are permanently dependent on their particular siting or interaction with other artefacts. Thus, while institutions, trades and activities question their very existence, the architects and planners are tearing their guts out looking for new ways to justify such existence. (Chester will not be destroyed by a demolition order approved by the Royal Fine Arts Commission; it will die when the last antique-boutique operator and his clientele are bored with hobbling over the cobbles and move out.)

However, architects and planners are desperately dedicated to trying to inject or discover some relevance in civilized man's aged-artifactual droppings – 'keep the cars out, build a by-pass, slap a preservation order on the front and some more square feet on the back'.

If architects and planners were a little more modest about the debt society owes them for possessing such fantastic three-dimensional awareness, and a little more conceitedly optimistic about the immense acceleration they, through their expertise, are capable of giving to the progress of ordered social change, they might in fact warrant attention from the rest for their other qualities. At the present it is difficult to find good reasons why they should not be ignored totally. (Salvation through Shell does not need That Tower to drive the message home while one can Make Money with...; while no one requires a monument to the turning circle of the family car at the Elephant & Castle.)

Over-hot imagery in built form appears to be in inverse proportion to the importance of the activity it houses. ('If St Pancras Station is to go then its successor must be even more gloriously recognizable,' they said, stepping over the National Computer Grid.)

I believe that a large proportion of the task of providing either in-built flexibility or planned obsolescence has already been taken out of the hands of the architects and planners at the physical scale of particular artifact or locale. This has occurred through the allied professions' incapacity to help, but the next phase of life-conditioning has yet to be undertaken. Such a phase requires a far more deliberate application of an expendable aesthetic in which, of course, determination of valid social life will be required for all artifactual decisions, being a necessary constituent of such an aesthetic.

This involves the recognition of the fact that as the even availability-network of

laboratory to factory, from information centre to home, and from one home to another. They would be taught in rail-buses, on the move or in sidings, utilizing to the fullest extent the existing rail network which has become unsuitable for high-speed traffic (there are far too many halts and junctions) but is ideal for a regular service picking up people at frequent stops. For students would live all over the area. Their dispersal would mean that they would not live within a self-conscious and artificial 'student-community'. They would be members of a whole community, living and working together. So that, teaching factories and rail-buses apart, the greatest emphasis is on living units. These would be put wherever possible and wherever required. They would not be tied down to static civic and social centres – which don't in any case seem to work. Living units, like teaching units, would be moved whenever necessary: they would be expandable and, of course, expendable. No one would be straight-jacketed into a fixed community.

invisible services increases in both intensity and content (Credit Cards and communication satellites) the residual activities requiring physical location, hardware and access become more particular or 'to taste'. (The wine and food socialists have always been able to send meaningful articles to the Statesman from the South of France while no one cares where Cadbury's Milk Chocolate is made.) This in fact becomes a far more critical conditioning task for the architect and planner, since he can no longer take refuge in decision-making as a result of determining the LCD, for it need no longer exist – in his realm, at least. Thus the consciously planned and purposely built environment that exploits the potential of unevenness of environmental conditioning is likely to become one of the main contributions that architects and planners can make to society. The obvious danger is that the undertaking of such a task will result in a further contribution to the soul-destroying static fixes in which architects and planners take refuge. (The publicly embarrassing back-peddling on the definition of 'a balanced community' from the New Town Mark 1 version, demanding juxtaposition of income (class) groups, to that of the Hook Plan, requiring merely an even distribution of age groups, has not rid us of the planners' determination to try to pre-determine the 'Good (collective) Life'.)

However, once architects and planners rid themselves of the idea that they are capable, through that which they leave on the ground, of re-orienting the past to the advantage of the present generation, then it is likely that the following objectives can be undertaken in the cause of life-conditioning only by good architects and planners.

The architect/planner must exercise all his expertise, on being asked for artifactual conditioning, on the relevance or necessity for doing anything at all. (The best technical advice may be that rather than build a house your client should leave his wife.)

A realization that image-making has passed from Easter Island via the Cathedral Builders to International Publishing Corp., and that architectural imagery in the minds of observers is always related with delight to the personal relevance of the observed object, even if only a building.

Decisions requiring re-allocation of effort or endeavour on the part of the client should also be suggested by the architect

or planner. Thus the writing of the brief in relation to, say, the housing of increased population, must be done by the planner and not the Treasury. ('We want a town of 250,000 people. Tell us where to put it and what it might look like'.) The acceptance by the designer of the ephemerality of existing definitions of collective conditioning kits such as 'house', 'overcoat', 'commuter service', and 'shop'. (It would be encouraging if architectural students were less concerned about the shape of a window and more concerned about what might come through such a shortsighted opening.)

It is rather pathetic that, while the appearance and performance of clothes, food, furniture, motor cars and wives/husbands is now considered a subject worthy of only limited-term personal predilection, the value judgment on a house or town is not for the users to make but for posterity.

With these objectives in view the Dukeries Thinkbelt is proposed. Underlying its proposals are the following intentions: The housing of a major activity such as education should be viewed in architectural terms as a demand to increase the availability of such a service on a national scale, though its dispensation may through necessity require a limited locale. This would appear to be in opposition to current higher educational practice where the containers are dressed up to look like a medieval college with power points and are located in gentlemanly seclusion.

An activity that will increasingly occupy a large proportion of everyone's life should be in contact with areas near and far where the rest of life is to be spent.

Education, if it is to become a continuous human-servicing service run by the community, must be provided with the same lack of peculiarity as the supply of drinking water or free teeth.

A major industry, as a source of employment, wealth and delight, must be capable of being implanted and eventually supplanted, with the minimum amount of physical (i.e. built) fuss in order to avoid, in the case of the Thinkbelt, the Dukeries being branded for all time as the ideal spot for scientific education. (Think of the terrible fate that befell that rather pleasant little East Anglian market town.)

Through its form and operation it provides a test-bed condition for large scale peculiar 'imbalanced' urbanistic development.

The role of architecture as a provider of visually recognizable symbols of identity, place and activity becomes an increasingly attractive excuse for architects to revel in the immensity of their personal visual dexterity, aesthetic sensibility and spatial awareness, demanding from both

clients and observers recognition of the very causations of such revelry. Call it a fix or 'the image of a city', such overt self-consciousness is embarrassing only to a few – in general, it is both incomprehensible and irrelevant. I think more architects should keep

the words clarity, coherence, mood, quality, conviction, presence and power to themselves. I doubt the relevance of the concepts of Town Centre, Town and Balanced Community. Calculated suburban sprawl sounds good to me. I think the duplicity behind the pleas

for pedestrians and The North disgusting. The possibility should not be ignored of Great Britain's becoming an increasingly imbalanced community primarily involved in servicing other countries and providing facilities for hardy historiophile holidaymakers.

DTb

Dukeries Thinkbelt

A plan for an advanced educational industry in West Nottinghamshire

Norman Fellows (after Cedric Price)

Valuable information and assistance was given by Roy Landau; Professor Stanley Mathews; Tyrrell Burgess; British Rail; Municipal Architect's Planning and Reconstruction Department, Kirkby-in-Ashfield; Municipal Engineers and Surveyor's Department, Kirkby-in-Ashfield; UK Fashion and Textile Association; Ministry of Labour; National Coal Board; Public Health Department, Kirkby-in-Ashfield.



The prime weakness of the advanced educational system in Britain is a lack of awareness of both the correct scale and intensity at which such education should take place.

Institutions today are too small and too exclusive. Because advanced education is not regarded as a major national industry, it is in danger of failing to achieve both a recognizable social relevance and a capacity to initiate progress rather than an attempt to catch up with it. This study proposes a valid national and regional distribution of educational institutions. In addition, by postulating various means of exchange, using electronic static communication systems together with mobile and variable physical enclosures, the study adumbrates the requisite flexible physical organization and the variable value of a finite location. Defence, energy and commerce have in the past been sufficient generators of cities. This project assumes that education and the need to exchange information may have a similar generative force: cities can be made by learning. The fashionable analogy between existing Universities and ideal towns is dangerous.

A firm re-assessment of housing requirements together with an avoidance in the first stage of development of any *civic design* indicates the real order of priorities.

Further education and re-education must be viewed as a major industrial undertaking and not as a service run by gentlemen for the few. Its resultant quality must stimulate its further use and not, as at present, merely enable statisticians to predict future demand under present conditions.

The DTb is planned to break down the isolation and peculiarity associated with further education. It is large enough to involve the whole community and thus to make people realize that further education is not merely desirable but essential. *Grants* must become *salaries*.

West Nottinghamshire – including the coalfields – is less prosperous than the rest of the region.

As far as built physical environment goes it is a disaster area, largely unchanged and uncared for since the middle of the twentieth century.

With a population of between a third and a half million concentrated in the towns, the surrounding country is easily accessible.

Proximity to both national routes and patterns of movement is at present unexploited. The

industries – hosiery, shoes and metals – though once prosperous, show little or no sign of a major recovery. The major industry, coal, has contracted.

Further education facilities including technical colleges and Workers' Education Association, are fragmented. One of the last post-war New Universities, formerly a Polytechnic, Nottingham Trent University (student population approximately 24,000), has little contact with the area and no faculties related to its industrial activities. There is a large movement of University entrants to other major Midland Universities – Birmingham, Manchester, Nottingham, etc.

DTb plan

Its size, 20,000 students, is such that its effect will be national rather than regional. Thus its relationship to all other Universities will be unaffected by their location.

The emphasis on science and industry should produce closer links with similar faculties in other universities, diminishing their self-contained quality.

Primarily the DTb will be a major industry, providing a wide range of employment for the population of the area. The usefulness, one to the other, of the DTb and the existing community will be two-fold. The DTb will encourage desperately needed tuning-up of the area's socio-civic amenities, while closely integrated local industries will act as direct physical links with the faculties.

The development is planned to allow advanced education to take full advantage of the present means of individual mobility. Equally, it is designed as to prevent its form and organization becoming restrictive.

Full use is made of technological resources usually reserved for post-academic activities. It is intended to replace the existing rigid age and time structuring of university occupancy with a more elastic system enabling full participation by part-time and re-education factions.

The DTb bias towards pure and applied science and engineering requires an emphasis on a flexible organization of faculties with easy links to national networks.

A far greater mobility of students between all educational establishments is envisaged. This necessitates calculated 'slack' in the educational facilities.

At present, a special and artificial status is accorded student housing, ignoring its position within the community living cycle. The DTb programme reverses this by accepting the student as an integral part of the Local Authority housing programme, but using the 3-5 year student cycle as an opportunity for hot-house research into new living patterns. The requirements of the student population will approximate closely to the future pattern of a literate, skilled and highly mobile society; the size (approximately 20,000) will make economic a far greater degree of choice than is at present practicable. The four housing types proposed place little strain on the building industry in the area, as a major part of the construction will be undertaken by other industries – possibly national.

Similarly, land at present considered unsuitable for housing is to be used. Packaged power generation and sewage purification plants will not only place no additional strain on the existing services network, but enhance it to the benefit of the community as a whole. The location of the housing areas will produce suburban sprawl, which, when planned, will reinforce existing urban settlements without making impossible demands on their physical communications structure. Such planning will help to increase the individual's freedom of movement rather than order it.

The total capacity of housing is approximately 40,000 which does not include the areas shown for future expansion. It is envisaged that occupancy by those directly involved in the DTb, together with the increased population caused by the development, will be phased with those already on local housing lists. At every stage a proportion of the new housing will be occupied by non-DTb personnel.

A progressive increase in the number of car-owning students means that the ultimate passenger-carrying capacity of the DTb rail net will not be a determining factor in the size of the DTb. Although re-location of equipment will become a progressively more important part of DTb rail activity, student transport by scheduled railbus services will remain a fundamental function of the rail net. Similarly, the outer triangle of the road net having a potential capacity far higher than it carries at present, the introduction of more sophisticated information transfer equipment to housing units will cause a levelling-off in usage before saturation

* East Midlands Regional Study HMSO 1965.

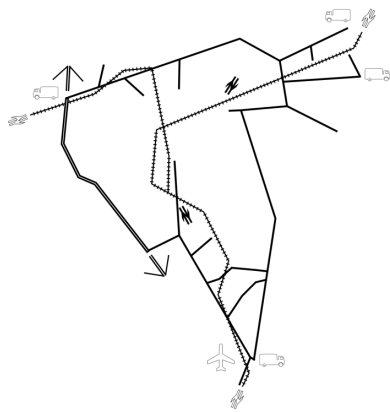

1
1
Diagram showing the road and rail network of the DTb, with national transport links

2
Map of the DTb showing main routes, transfer, faculty and housing areas - Produced for Buckminster Fuller Challenge

3
Diagram showing the primary road net of the DTb with desire lines of linkage between housing and faculty transfer areas. Desire lines between faculty and transfer areas only are shown dotted

4, 5 & 6
Montages on aerial views of the three main transfer areas at Teversal, Clipstone Colliery and Hucknall, with an indication of their distances apart.

point is reached. The use of the outer triangle as a ring-road will effectively reverse the situation implicit in the existing situation and Local Authority road proposals where traffic is to be concentrated in congested radial arteries. A choice between road and rail transport and the use of non-physical links between students and information stores, except in the case where actual physical contact is important, will allow students to discover the method and rhythm of study most suited to their capabilities. National transport links occur at the apices of the DTb triangle - at Clipstone Colliery to Hull, Leeds and Newcastle (road and rail); at Teversal to Hull, Leeds, Sheffield, and London (M1); and at Hucknall to Nottingham (road and rail) with international air links via Hucknall. Kirkby-in-Ashfield station provides a direct rail link to London via Rugby and Leicester. Advantage will be taken of the existing rail network and stations. The Teversal and Clipstone Colliery limbs of the DTb were surplus to British Rail's passenger carrying requirements and were closed to passenger traffic decades ago. The very conditions which make the Clipstone Colliery limb, in particular, uneconomic for normal passenger working - numerous stations at extremely short intervals - make it extremely well suited to DTb working by railbus with continuous as opposed to peak travel. The Hucknall limb of the rail net, though open to passenger working again, is not a main line and does not carry unduly heavy traffic. Interaction between facilities and existing industry will be, at once, a short-term benefit

to both. These links will be of a temporary, flexible nature as detailed in the faculty plant. Long-term operational links with both local and national industry will demand a capacity on the part of the DTb to build and sustain experimental plant of the type now confined to the very large industries and state institutions. The present shortage of such capacity is evident in what were colleges of advanced technology (eg Bradford). National links are achieved by the provision of the transfer areas for rapid movement in bulk and quantity of people, goods and hardware in and out of the DTb network. The subsidiary activities of the student population will enable the community as a whole to benefit from new and specialized plant leisure and recreation. Similarly, the information and learning facilities provided by the DTb are to be used by the whole population. The system by which the public is self-consciously invited to participate, on sufferance, in certain activities in existing universities will not obtain in the DTb, since the flexibility of learning equipment and methods will allow national participation by students in fields at present rigidly defined as secondary or adult education. Though the effect of the DTb in providing new forms of employment directly related to the complex will be of short-term benefit to a community once heavily dependent on a single basic, now contracted industry, the long-term value of the DTb will rest on the capacity of its research facilities to attract new industries to the area and to reorientate and revitalize existing industries such as energy production.

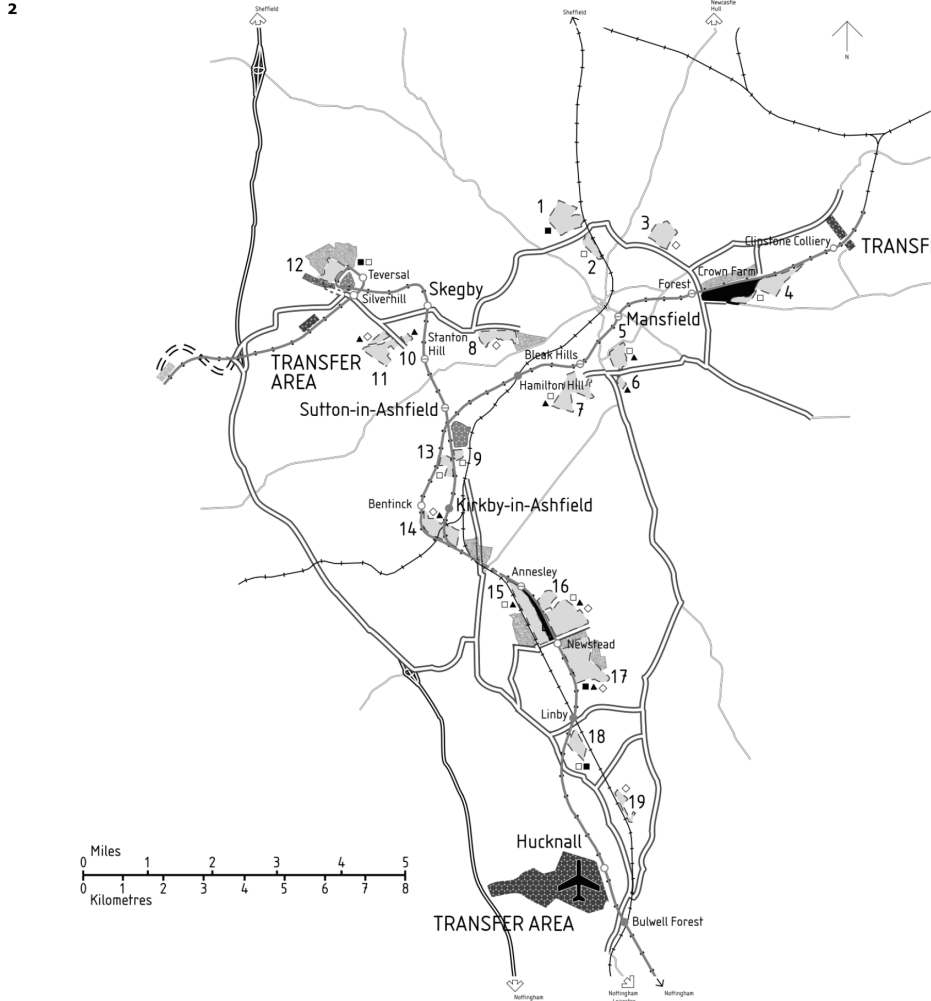

- DTb = Dukeries Thinkbelt
- ==== DTb service roads
 - ==== other roads
 - ==== DTb service railways
 - ==== other railways
 - stations -
 - DTb & public use
 - DTb use only
 - ⊙ with small siding
 - housing areas
 - capsule housing
 - ▲ sprawl "
 - ▲ battery "
 - ◇ crate "
 - ▨ housing expansion area
 - ▬ faculty area
 - ▨▨▨▨▨▨ faculty/industry shared
 - ▨▨▨▨▨▨ transfer areas

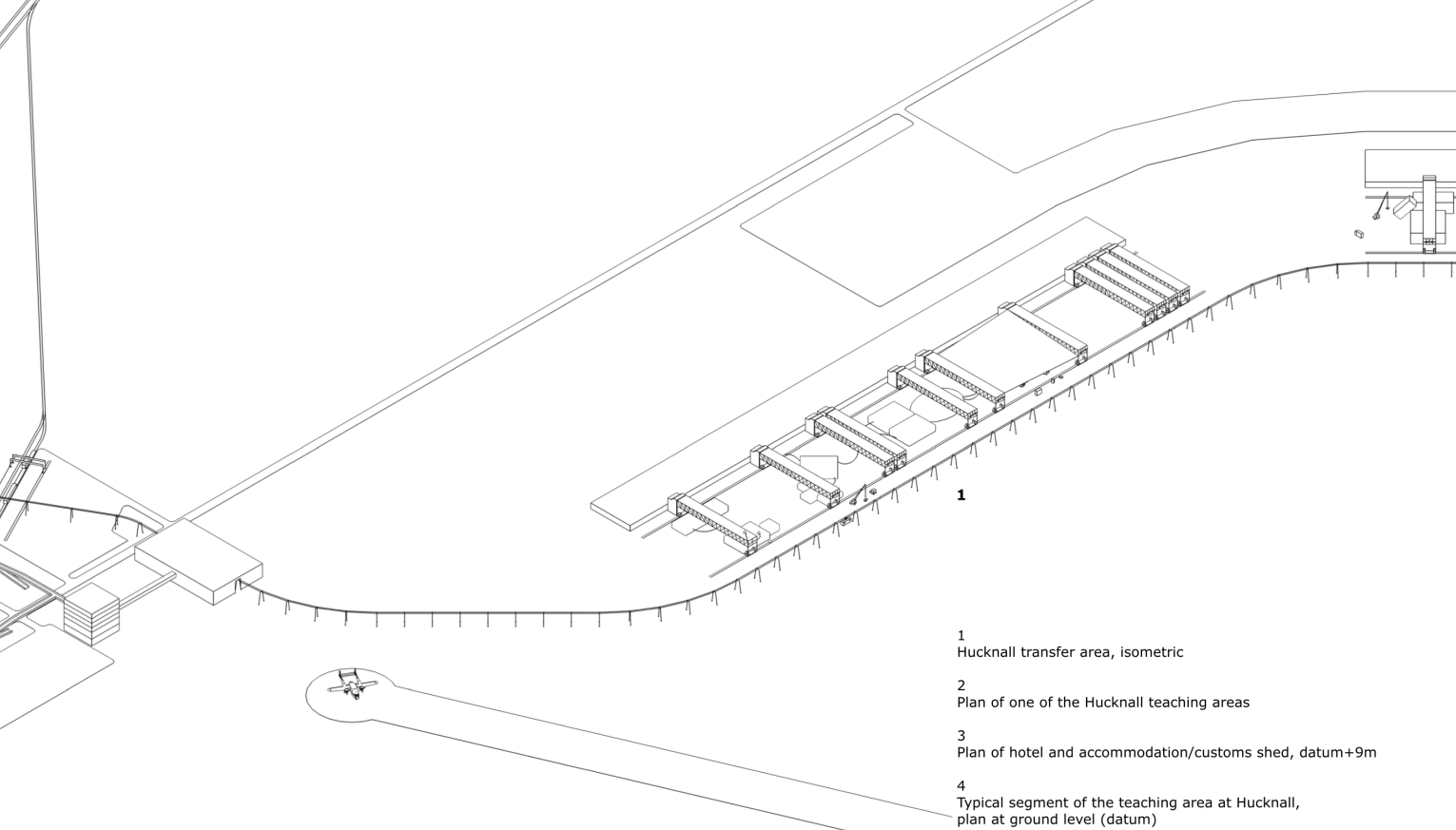

- 1 Hucknall transfer area, isometric
- 2 Plan of one of the Hucknall teaching areas
- 3 Plan of hotel and accommodation/customs shed, datum+9m
- 4 Typical segment of the teaching area at Hucknall, plan at ground level (datum)

Hucknall Transfer Area

A road-DTb rail-air link providing facilities for rapid exchange of personnel or lightweight goods from DTb to national or international networks.

Work accommodation for students and staff (single floor) leading directly to rail-based laboratory and servicing gantries travelling over and providing access to a zone reserved for short-term portable enclosures.

Provision is made for banking the galleries for linked use. High-level partial enclosures can be created between gantries. A monorail goods feed joins the two blocks to an inspection, storage and customs hall connected to the accommodation block and the road/rail links.

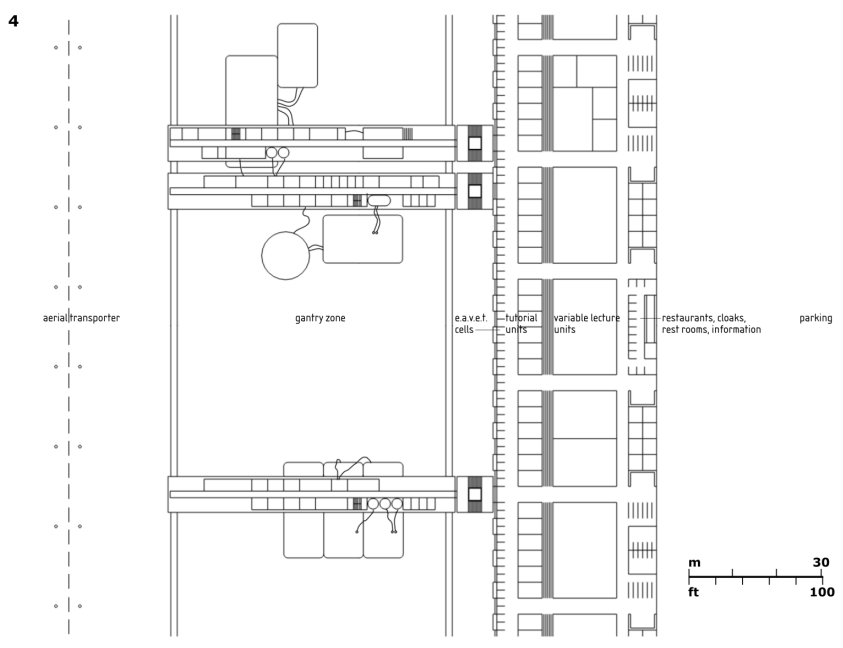
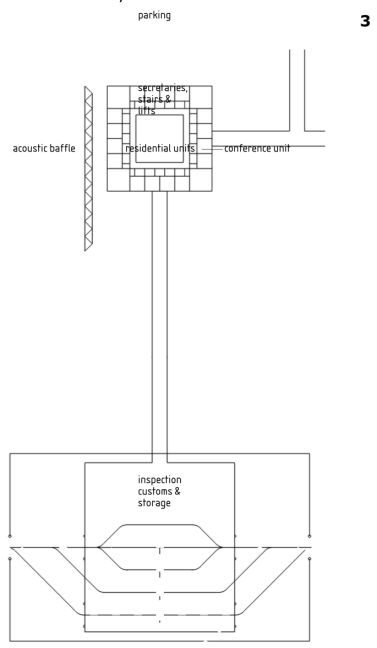
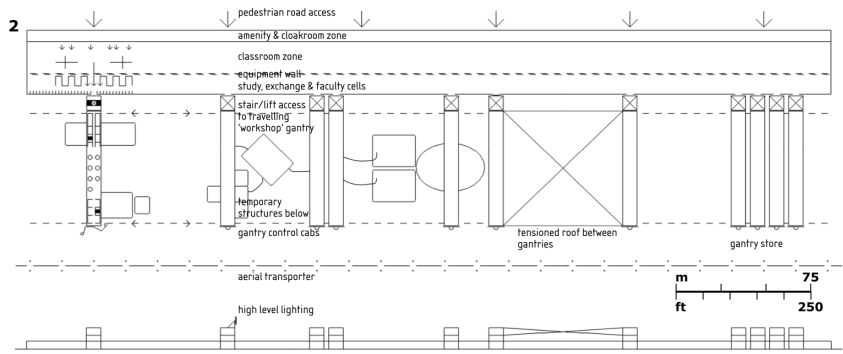

Clipstone Colliery Transfer Area

A national rail-DTB rail-road link providing facilities for rapid and continuous bulk goods and personnel exchange. Valley sited vertical and horizontal communication for goods and people offers conditions for the large-scale installation of experimental plant, etc.

A serviced plant pit adjoins an open floor area for small temporary enclosures which is covered by a serviced accommodation deck containing living and working cells, and is the equivalent in its operation to the large static gantry installed at Hucknall.

The accommodation would be for those involved in continuous processes being undertaken in the transfer complex.

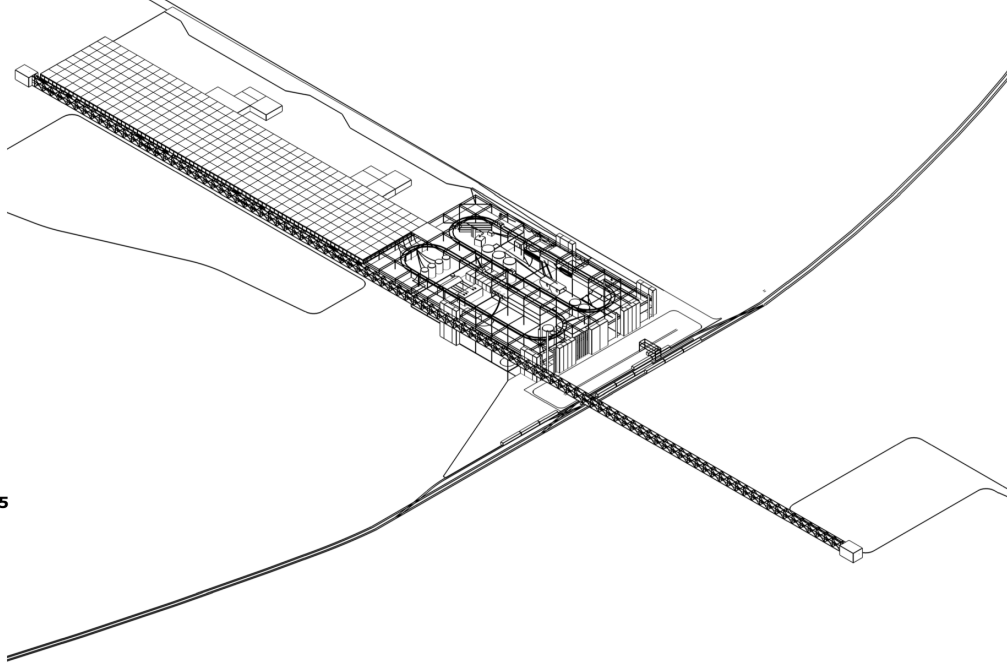

5

5
Clipstone Colliery transfer area, isometric

6 & 7
Diagrammatic plan and section of Clipstone Colliery transfer area

8 & 9
Typical segment of Clipstone Colliery transfer area, plan at ground level (datum) and datum+6m

10
Key to accommodation units in the transfer area

6

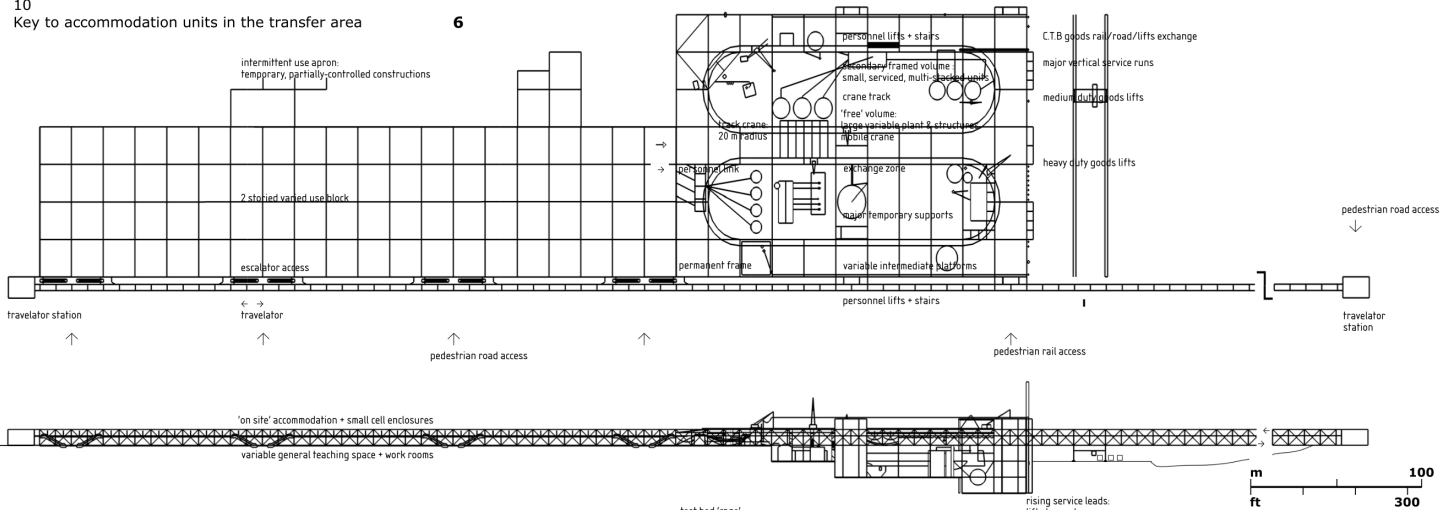

7

8

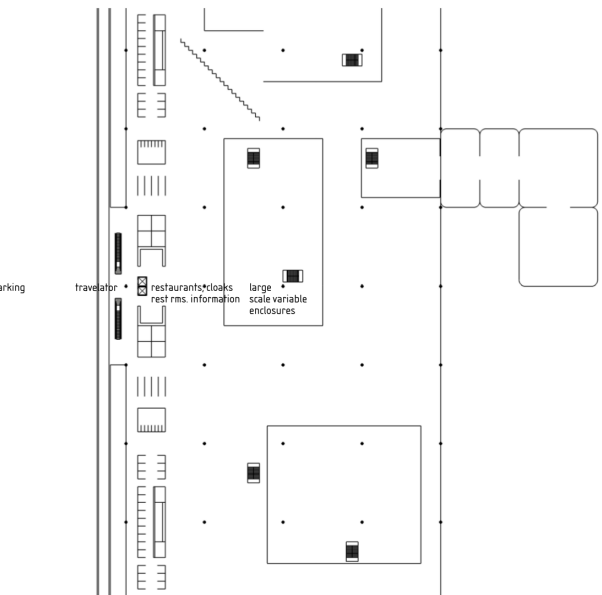

9

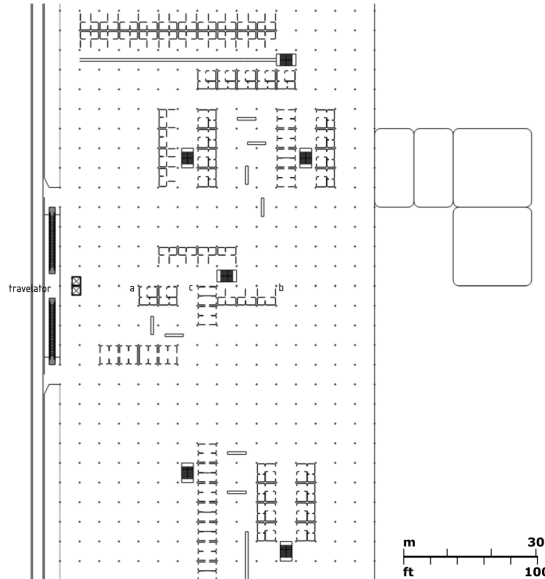

10

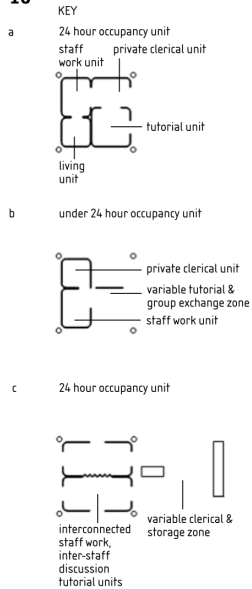

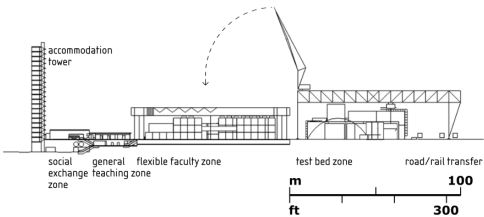
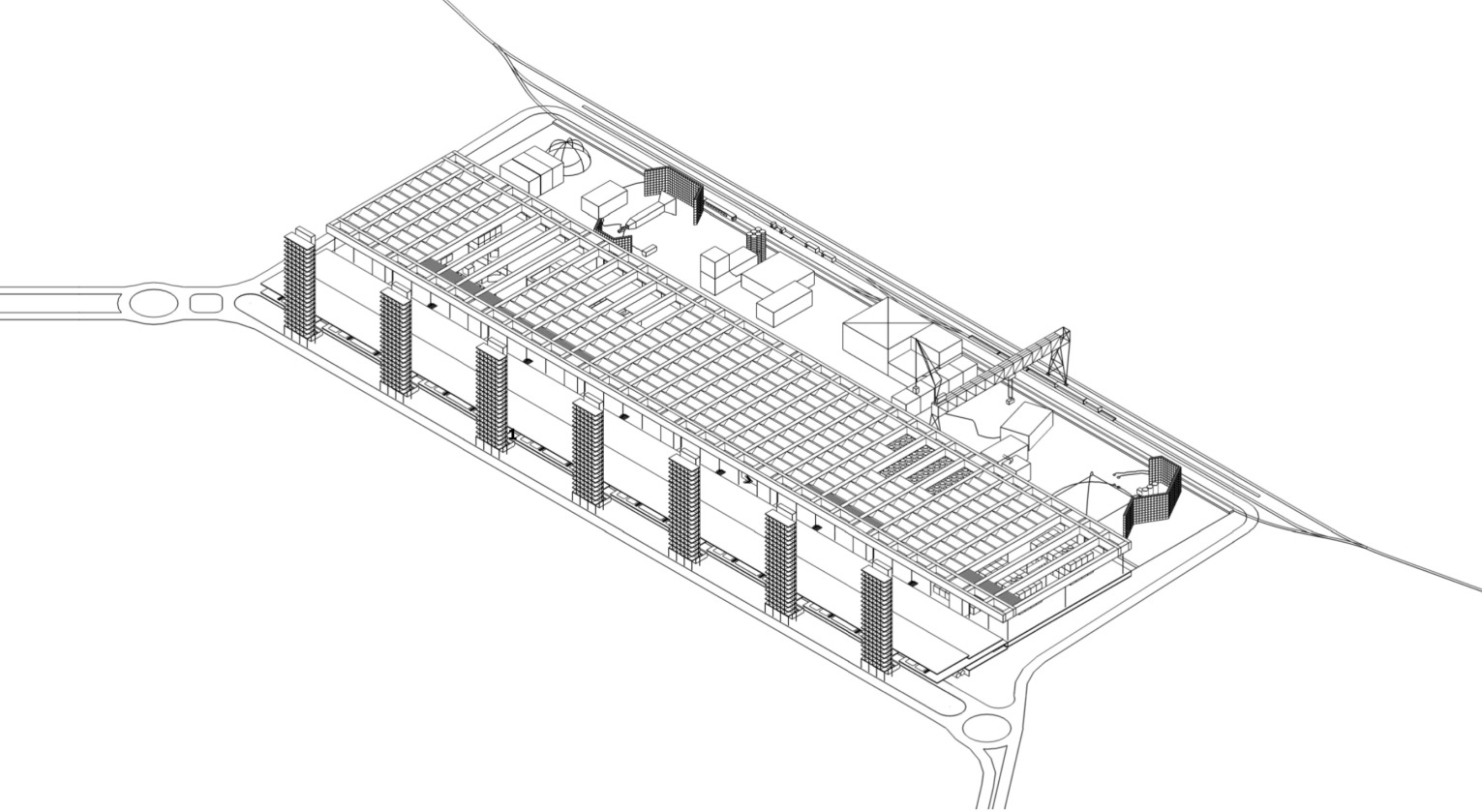

Teversal Transfer Area

A motorway-DTB rail-road link providing facilities for handling, assembly and construction of large-scale goods and equipment. Two workshop zones with adjustable high-level servicing and access are adjacent to conventional work areas capable of cellular variation which in turn adjoins reception, public and amenities areas. Rising from the latter are accommodation towers. These provide minimal hotel accommodation, and are likely to be used by short- and medium-term visiting staff.

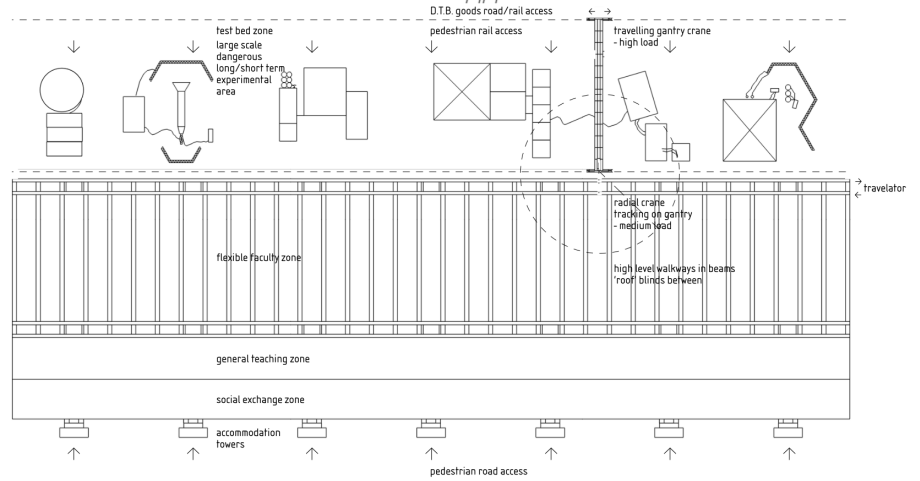

- 1 Teversal transfer area, isometric
- 2 Diagrammatic cross-section of Teversal transfer area
- 3 Diagrammatic plan of Teversal transfer area
- 4 Plan of typical segment of Teversal transfer area showing detailed organization
- 5 Montage drawing of the Teversal transfer area

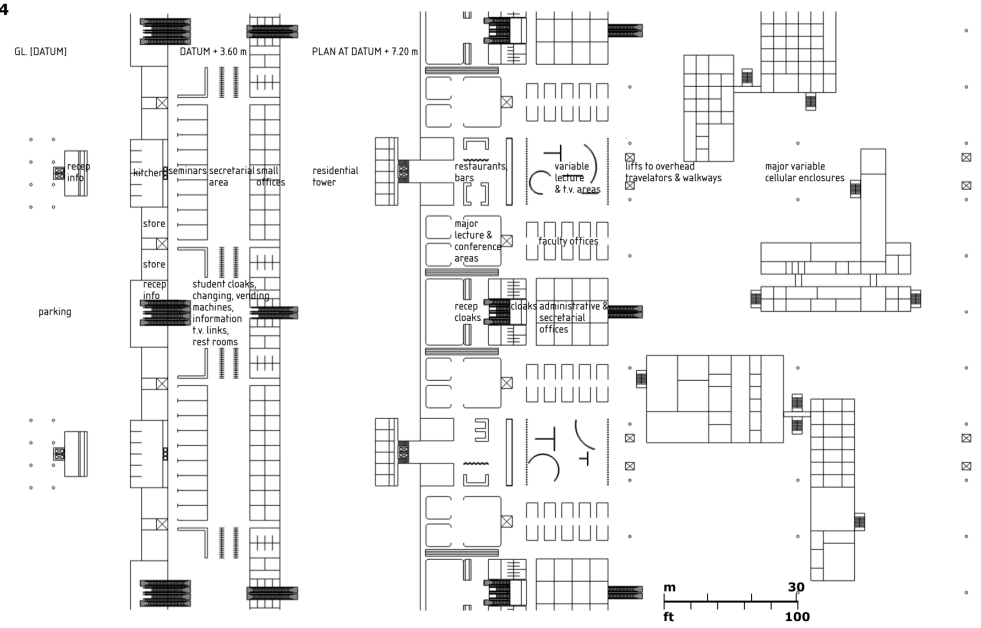

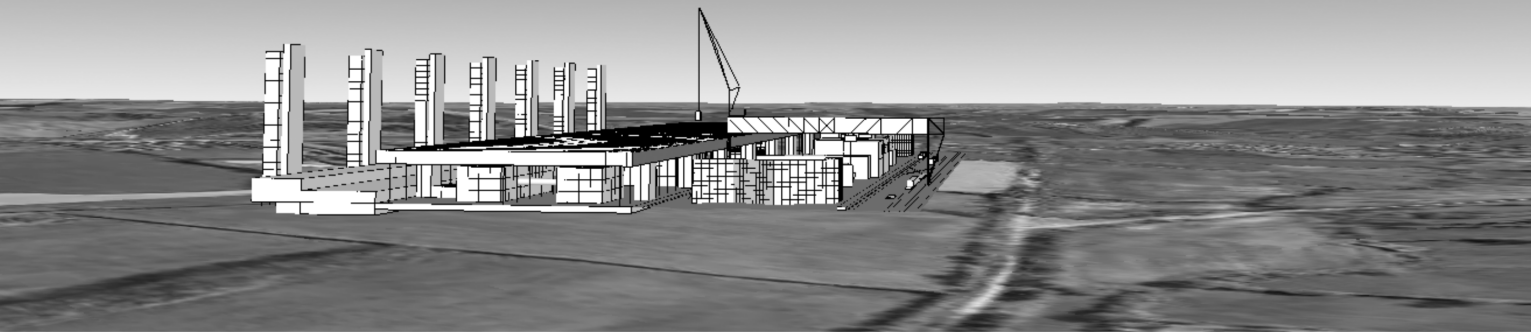

5 Faculty Areas

These provide for the immediate disposition of rail-based, mobile learning units as required by each faculty. Five types are proposed:

Seminar units. These may be used as part of the normal railbus services, or separately with stops of scheduled duration at DTb stations, providing opportunity for both scheduled teaching in student areas and random discussions.

Self-teach carrel units. Used in conjunction with closed or open circuit TV or linked information and programme store.

Information and equipment storage units.
Fold-out, inflatable units. Providing either two 30-person lecture areas or one demonstration/TV studio, linked to information and equipment stores.

Fold-out decking units. Used for either access to other units, or as support for specialized or fine-control rigid enclosures positioned on units by mobile cranes.

Separate units provide motive power and packaged services boosting faculty areas. There are three main faculty areas, one situated on each limb of the DTb rail net. They have new sidings built up in assembly zones, each capable of receiving up to 12 learning units, and separated by transfer zones for the removal and relocation of units.

Silverhill: 4 assembly zones. Stage 2 area dependent upon redevelopment of Silverhill colliery.

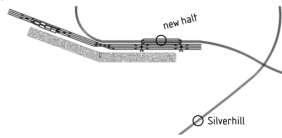

Crown Farm/Forest : 5 assembly zones capable of extension to the south.

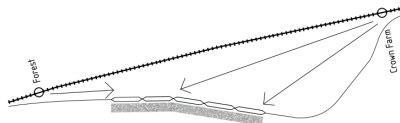

Annesley/Newstead: 6 assembly zones.



Newly created industrial sidings will be used as shared faculty areas for coordinated work between industry and the DTb – at Mansfield (Green Line Industrial Estate) and Silverhill (Silverhill Colliery). Small new sidings, generally at stations, will function as faculty sidings, used mainly for self-teach learning units and information storage

units, often for dual use by DTb students and the community as a whole.

Existing plant provided for any University will be used by DTb, but no extension is anticipated.

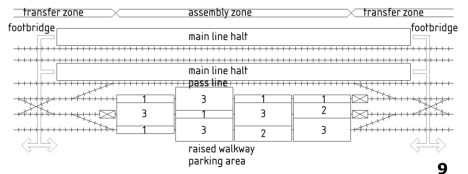

Diagrammatic plans of faculty areas: application of 'ideal' layout to actual sites

6 Silverhill: four assembly zones linked to parking areas by footbridge across the branch line. Area 4,994 sq m

7 Crown Farm/Forest: five assembly zones with adjacent parking area: pedestrian access across extended Vicar Water Country Park from Forest and Crown Farm stations. Area 6,243 sq m

8 Annesley/Newstead: six assembly zones in 'ideal' configuration. Area 7,491 sq m

9 Plan of 'ideal' faculty area rail assembly zone
 ☒ key services booster or motive power unit
 1 single width unit
 2 single fold-out unit
 3 double fold-out unit

10-17 Diagrammatic plans of rail-based teaching units

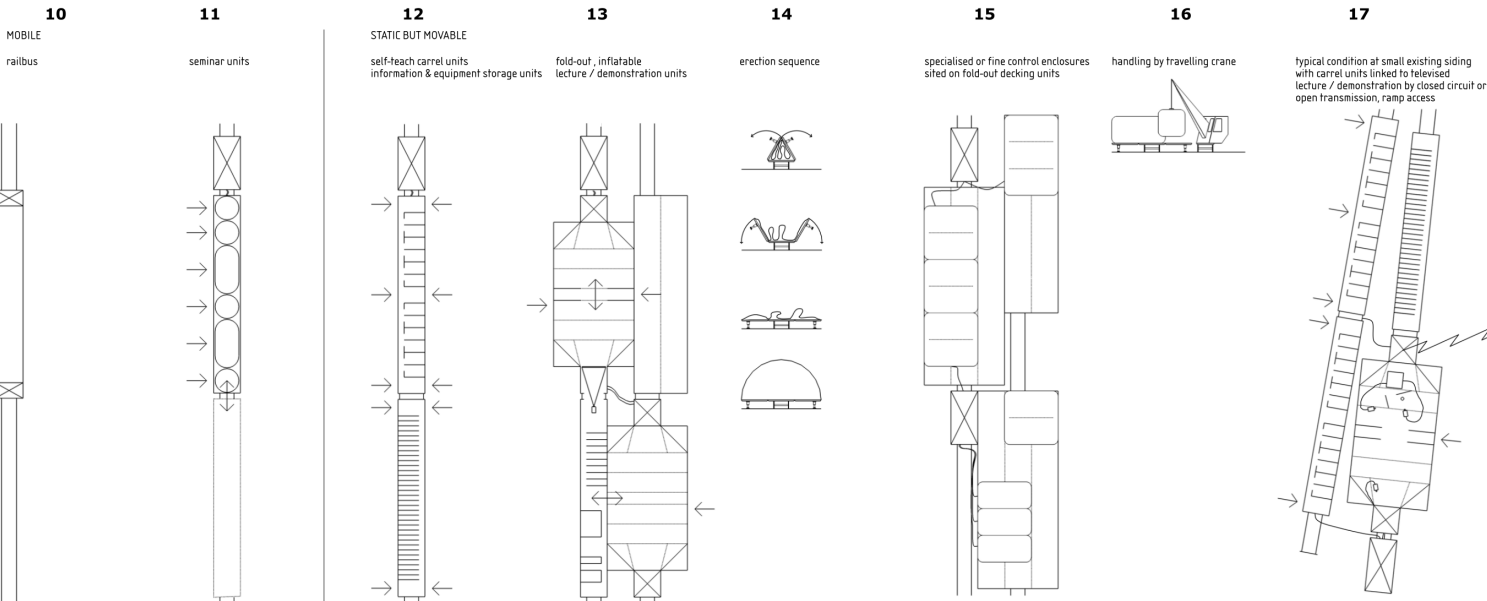

SITE CONDITION	CAPSULE	SPRAWL	BATTERY	CRATE
slipping, uneven, flooding or subsidence-prone ground	small unit size + linear layout allows use of steeply sloping sites with good views	small unit size, jacked supports and flexible service/access requirements allow siting in any ground condition	jacked supports allow siting on uneven, subsidence-prone ground	no application
unpleasant immediate environment	no application	circular layout avoids contact with immediate surroundings	'promenade' allows construction of autonomous open-air environment	detachment from ground gives visual release from immediate surroundings
good immediate environment	small unit size allows use of sites hitherto impossible for housing	'T' layout allows flexible siting with minimal disturbance to existing amenity	roof-deck parking variant	'fronter' condition at edge of built-up area

1 Crate housing

For use on reasonably level non-subsidence-prone sites. Permanent 13-storey reinforced concrete frame, pressed steel living units positioned by mobile hoist and gasket sealed to frame. Airspace around units provides acoustic insulation and background temperature control. The possibility of linking one, two or three units will provide variation in space usage, such as an increased demand for working area, while improvement in living standards is achieved by replacement of units with more sophisticated models.

- 1 Diagram of all housing types, showing application to various site conditions: total number of housing units provided 32,372 (excluding expansion area)
- 2 Cross-section through crate housing block
- 3 Longitudinal section through crate housing block
- 4 Isometric view of spine service leads and service catwalks in crate housing block
- 5 Diagram showing linkage possibilities of crate housing units
- 6 Part Elevation, giving some indication of alternative glazed closer panels
- 7 Section AA
- 8 Part plans of crate housing block, showing single and horizontally and vertically linked units
- 9 Section BB

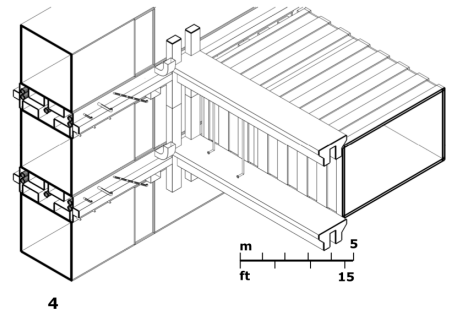
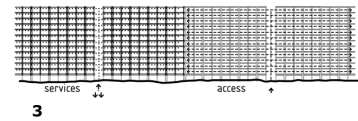
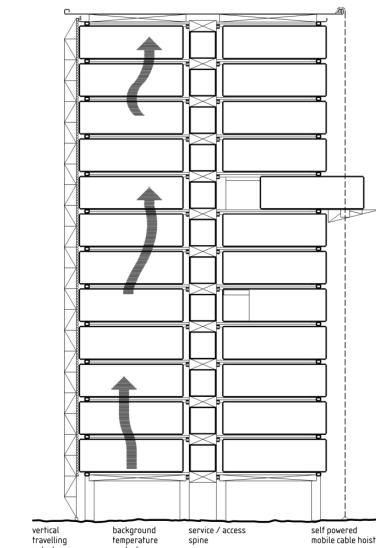

2

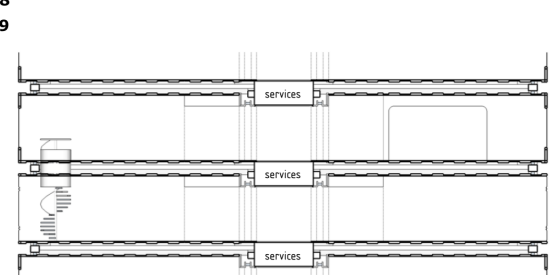
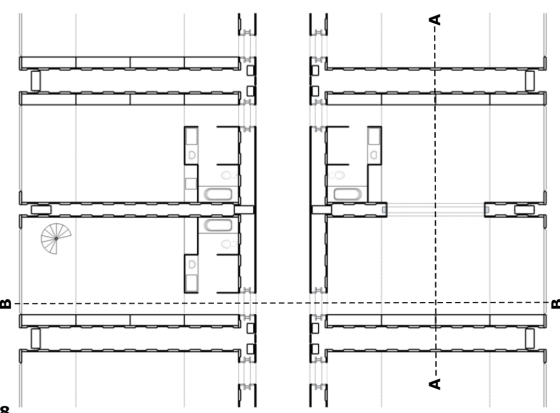
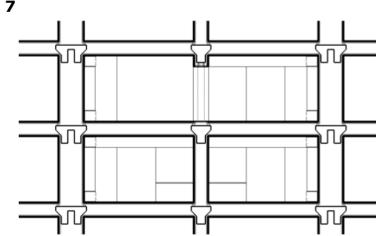
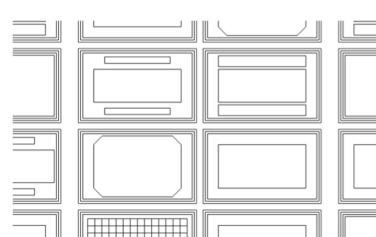

5

6

7

8

9

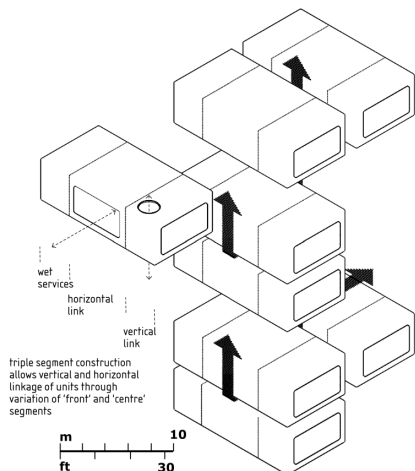

Sprawl housing

An additive system of timber-framed prefabricated units capable of housing families of any size or age. The use of a space-frame 'tray' with three-point jacked support will allow for siting on uneven, waterlogged or subsidence-prone ground. Grouping of units may be in 'open' or 'closed' formation depending on environmental conditions. In either case, units are serviced by 'packaged' heating, power and sewage purification units. All equipment except for wet servicing can be moved.

In general, a change in living requirements involves change of occupancy rather than extension or alteration of a particular unit.

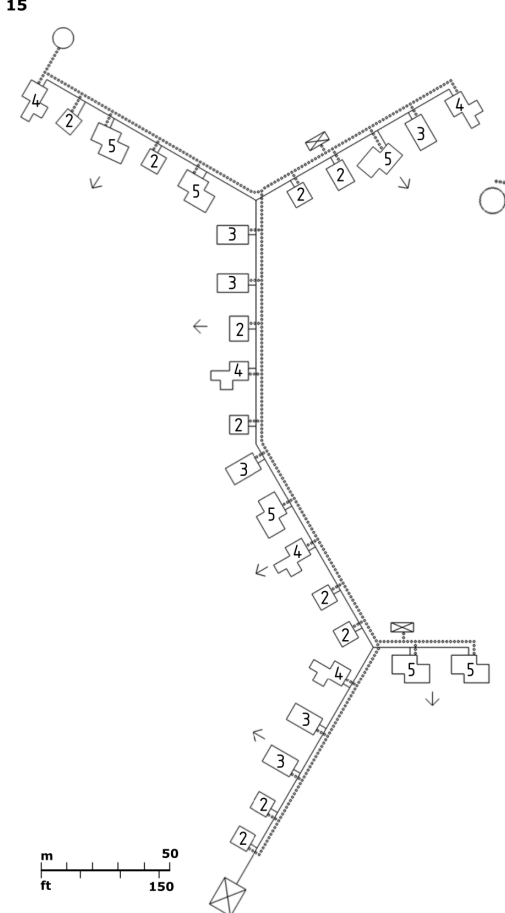
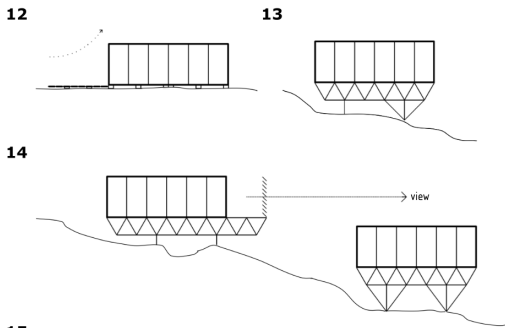
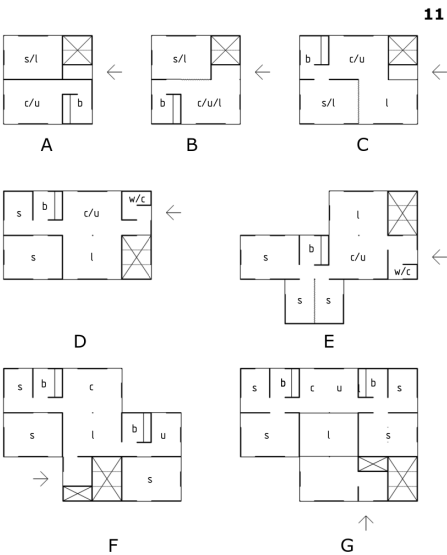
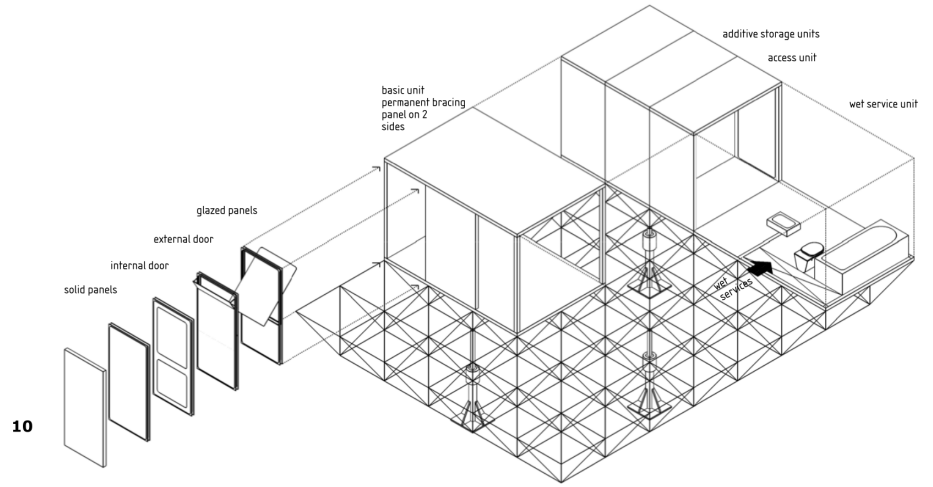

10 Sprawl housing: housing type A, isometric showing construction of basic and special units, infill panel range and jacked support structure

11 Typical house plans
 A, B, C maximum two persons
 D three persons
 E four persons
 F five persons
 G six persons

s sleeping
 l living
 c cooking
 u utility
 b bathroom
 w.c. extra w.c.

12 Simply-supported unit on even site

13 Space frame deck with braced three-point jacked support on uneven site

14 Sloping site allowing greater proximity of jacked units with integral private open space

15 Normal grouping of sprawl units in linked Y formation with packaged heating, water boost, and sewage purification plant

16 Circular grouping of units in unpleasant surroundings

17 Sprawl servicing used to provide temporary rehabilitation for existing housing with 10-15 year structural life

18 Sprawl units linked by service feeds to battery housing

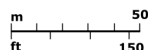

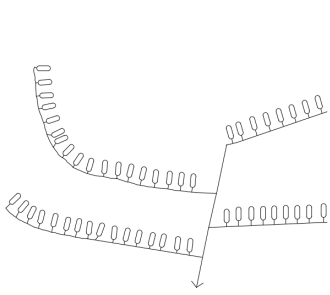

1
Capsule housing

Primarily intended for single person occupancy, though capable of short-term use by two persons.

The unit is factory assembled with a metal frame and fibreglass infill providing peripheral clear and translucent glazing. All equipment and furniture will be built-in to ensure maximum economy and use of space.

Units are positioned by means of built-in jacked **2** supports on sites of reasonable environment and/or good views. The self-contained nature of the units allows them to be used as a housing pool during the construction of other house types or during periods of unforeseen fluctuation in the living pattern.

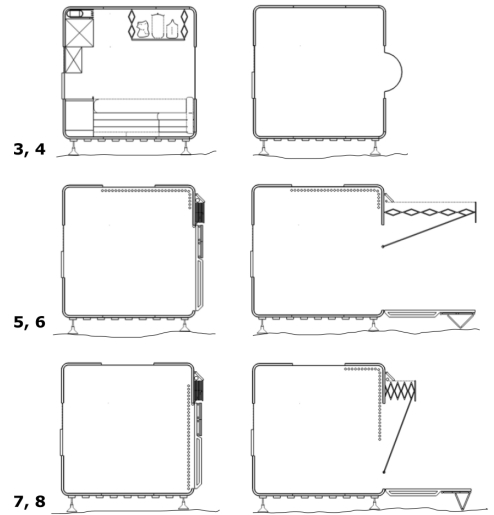
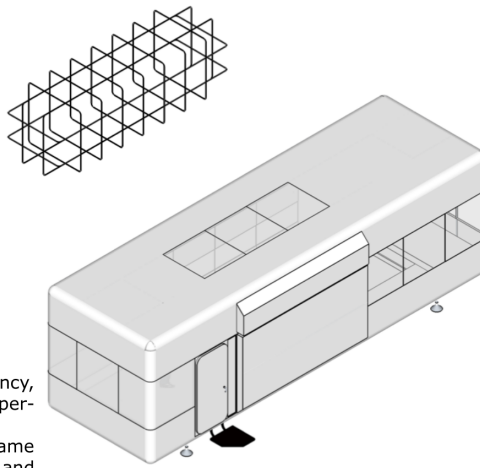

1 Capsule housing layout: wrap-around clear glazing and privacy control allowing positioning in rows without loss of view

2 Isometric of capsule housing showing structural frame and finished capsule

3 Section showing permanent and adjustable storage, fold-out seat or bed

4 Section with perspex viewing blister

5-8 Sections showing alternative arrangement of fold-out platform and canopy and the translucent roof panel and sliding shutter

9 Plan of capsule housing

10 Diagrammatic plan of capsule house, showing overlap of functional zones

11 Plan of typical site layout showing relationship of parked cars to capsule units

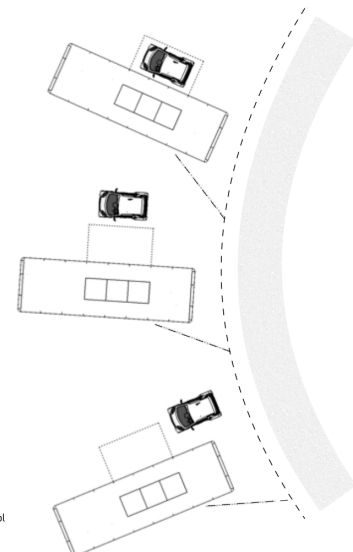
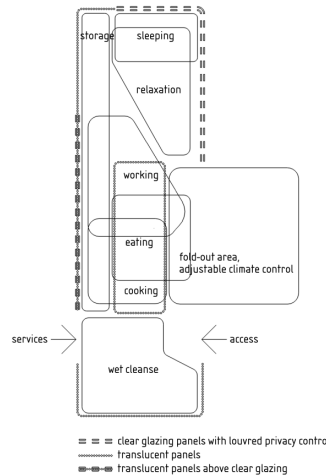
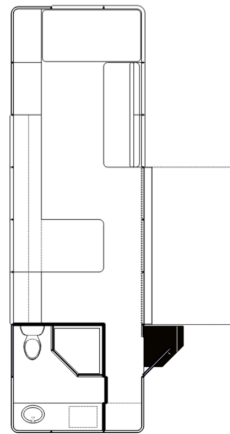

9

10

11

— = clear glazing panels with louvred privacy control
 - - - translucent panels
 - - - translucent panels above clear glazing

Battery housing

This consists of a sealed environment sandwiched between space grids containing a total servicing network. Subdivision of living units is achieved by non-loadbearing wet construction on a 5-7 year cycle enabling progressive expansion of space provision. (This element can provide foul-weather employment for the conventional building industry.) The roof area is used for self-contained 'promenade' activities (Variants A and C) or for parking (Variant B) where the immediate surroundings provide pleasant external environment.

Jacked supports allow siting on uneven or subsidence-prone ground: the basement area thus formed may be used for parking (Variant C).

12

13

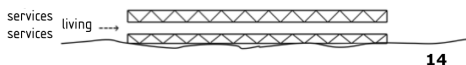

14

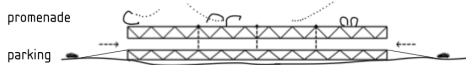

15

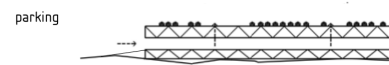
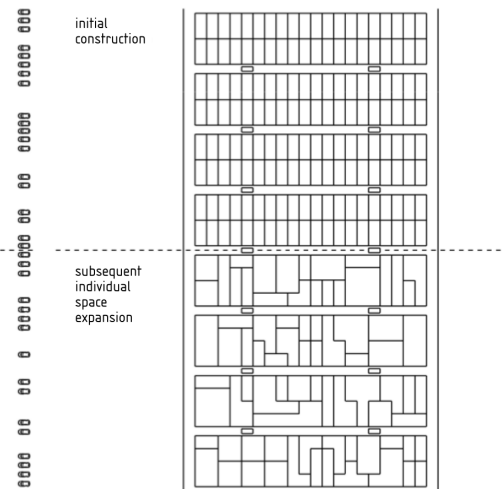
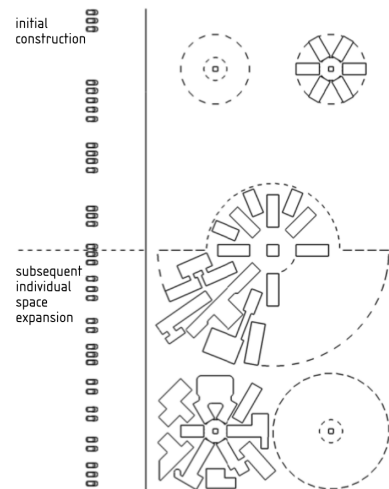

16

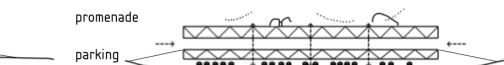

17

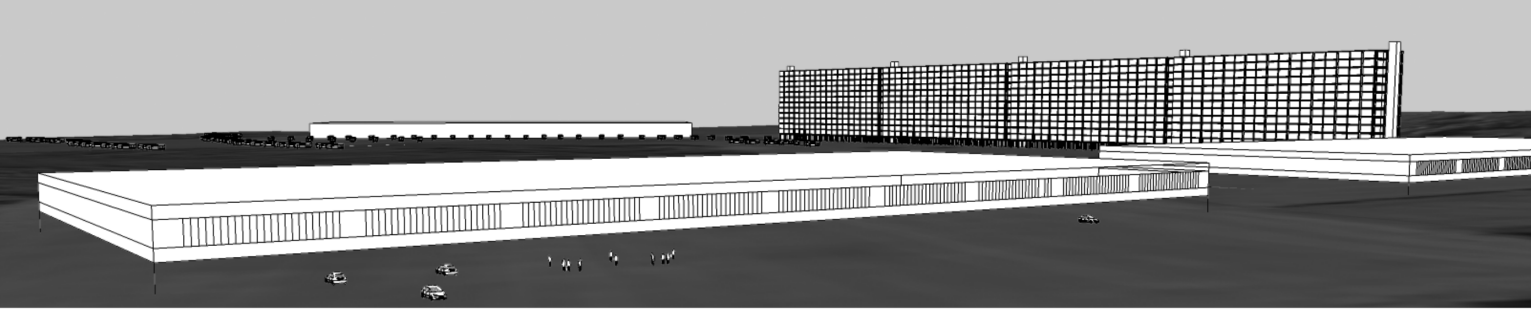

18

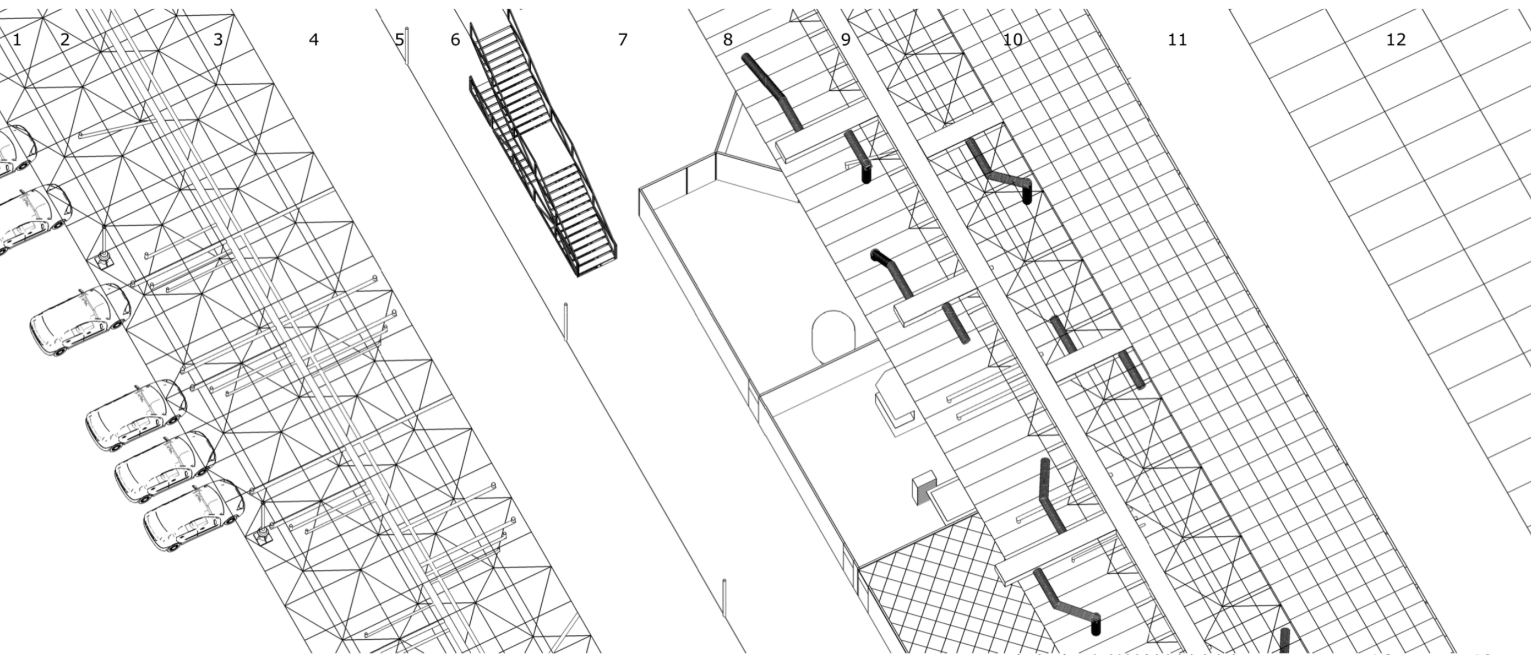

19
20

- 12 Battery housing: variant A, plan at living level
- 13 Battery housing: variants B+C, plan at living level
- 14 Basic battery housing system, section
- 15 Battery housing: variant A, section
- 16 Battery housing: variant B, section
- 17 Battery housing: variant C, section
- 18 Newstead site, showing battery housing with crate and capsule housing in the distance
- 19 Battery housing: cut-away isometric showing services
- 1 parking
- 2 fixed services within space grid
- 3 sound insulation
- 4 floor decking
- 5 structural supports to roof
- 6 stairs to roof and parking
- 7 living units: non-loadbearing wet construction
- 8 sound insulation
- 9 flexible services within space grid
- 10 thermal insulation
- 11 weather seal
- 12 roof decking
- 20 Perspective sketch showing corner condition of battery housing block

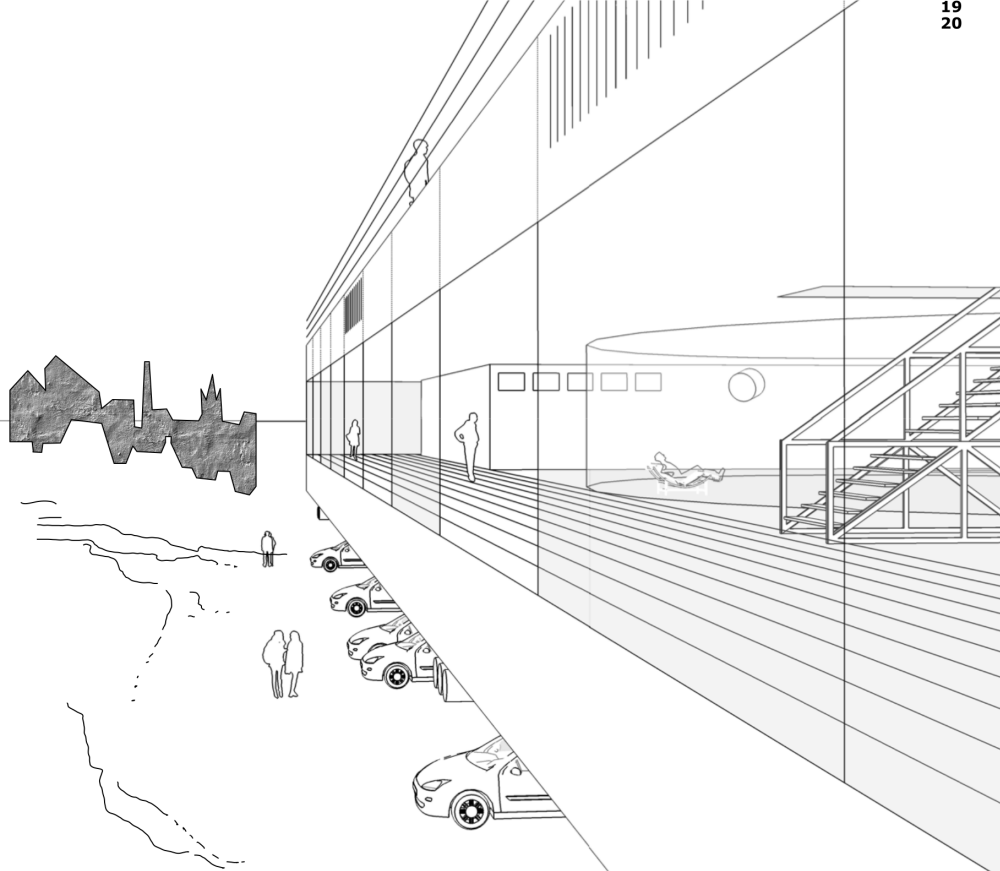

13

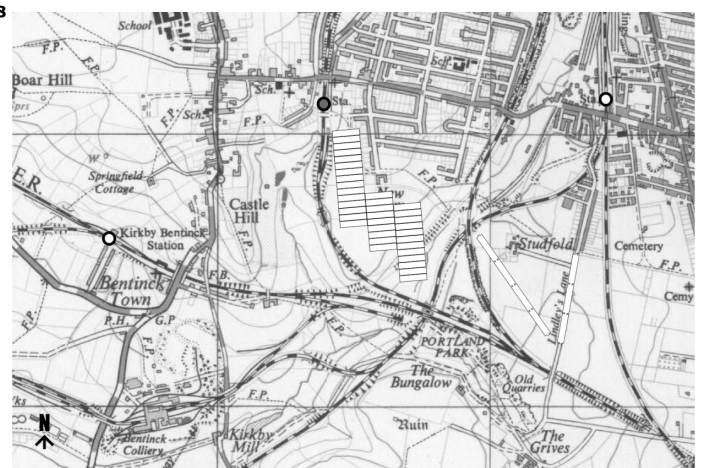
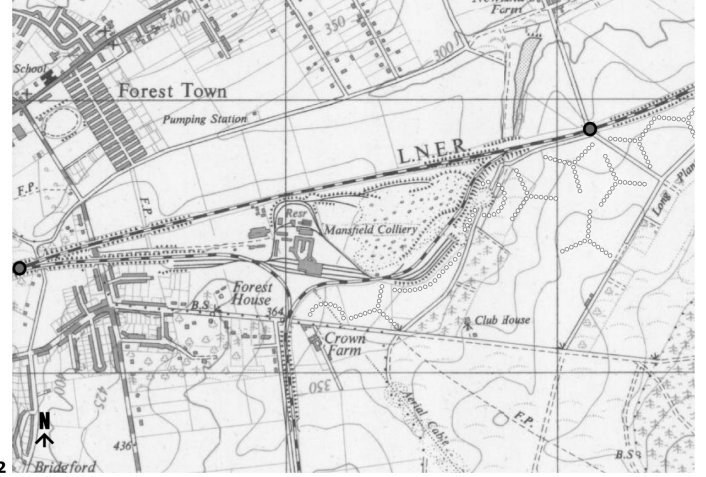



Layout of housing areas

(see position on key map page 4)

All drawings on pages 14 and 15 to the same scale

- 1 Housing areas 1, 2 & 3
site no. 1, 43.71 ha, 260 capsule units
site no. 2, 11.74 ha, 68 sprawl units
site no. 3, 12.95 ha, 2616 crate units
- 2 Housing area 4
26.3 ha, 26.3 ha, 154 sprawl units
- 3 Housing areas 5, 6 & 7
site no. 5, 21.45 ha, 28 sprawl, 756 battery units
site no. 6, 4.05 ha, 324 battery units
site no. 7, 50.18 ha, 148 capsule, 71 sprawl, 1638 battery units
- 4 Housing area 8
39.66 ha, 3924 crate units
- 5 Housing areas 9 & 13
site no. 9, 7.28 ha, 49 sprawl units
site no. 13, 15.78 ha, 114 sprawl units
- 6 Housing areas 10 & 11
site no. 10, 3.24 ha, 324 battery units
site no. 11, 20.23 ha, 1980 battery, 2616 crate units
- 7 Housing area 12
27.92ha, 70 sprawl units
- 8 Housing area 14
50.99 ha, 1422 battery, 3052 crate units
- 9 Housing area 15
46.13 ha, 69 sprawl, 1746 battery units
- 10 Housing area 16
64.75 ha, 191 sprawl, 288 battery, 3052 crate units
- 11 Housing area 17
51.8 ha, 431 capsule, 1080 battery, 1744 crate units
- 12 Housing area 17: axonometric
- 13 Housing area 18
10.93 ha, 70 capsule, 63 sprawl units
- 14 Housing area 19
19.42 ha, 3924 crate units

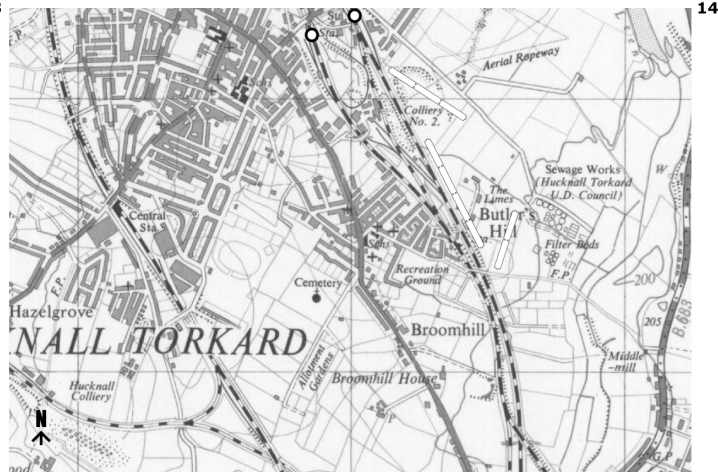
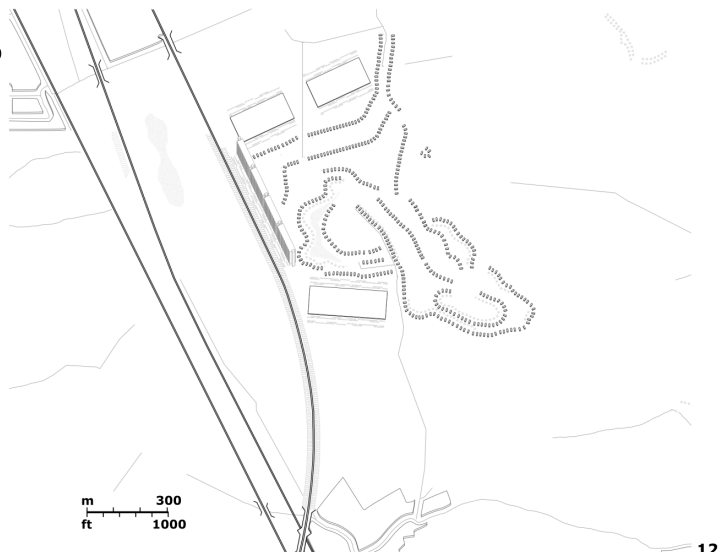
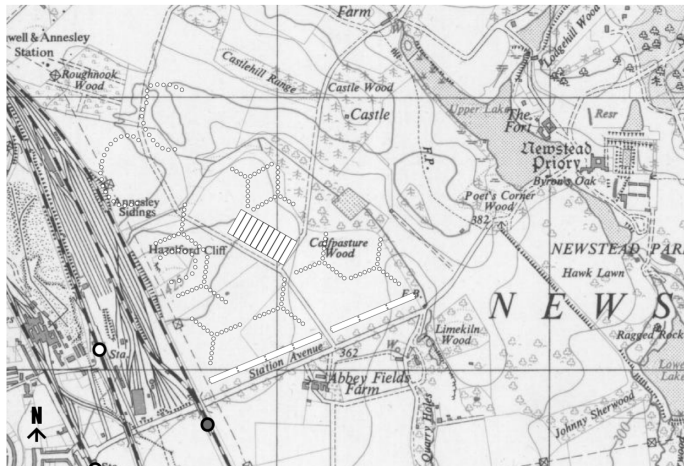

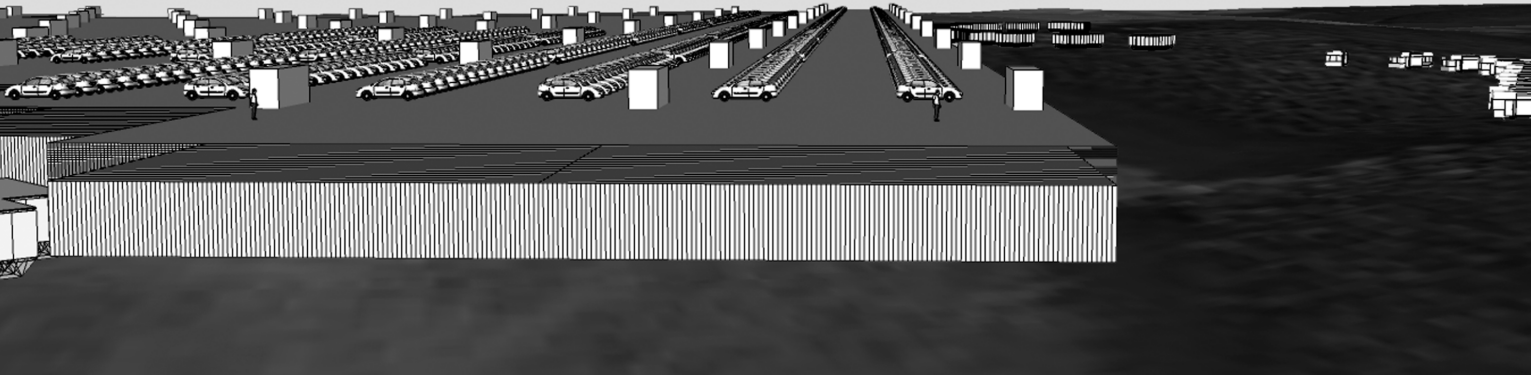

Socio-Civic Development

Housing and the provision of specialized leisure equipment will provide an immediate improvement in the environment. Housing sites 7 and 8 border King's Mill Reservoir which will be rehabilitated for recreational activities such as sailing and water-skiing, allowing access from the Sutton/Mansfield area to the open country beyond Hamilton Hill. Similarly, the erection of small scale specialized enclosures (such as squash courts) on the promenade of battery housing blocks can influence existing living patterns in the same way as packaged sprawl housing servicing used to improve adjacent sub-standard dwellings. Entrepreneurial instinct will rapidly satisfy demands for greater flexibility and choice at normal consumer level, but once the DTb begins to function, pressure by the whole community for more complex leisure and recreational plant will require coordinated action with local authorities. Though the DTb will, in a sense, be the instigator of such development, its main contribution will be its effect on the community as a whole rather than as a purveyor of 'amenity'.

Bibliography

New Society, 2 June 1966, 7, no. 192, cover and pp. 14-17
Architectural Design, October 1966, cover and pp. 483-497
From Agit-Prop to Free Space: The Architecture of Cedric Price, pp. 192-239, Stanley Mathews
Supercrit#1, Cedric Price, POTTERIES THINKBELT, Samantha Hardingham and Kester Rattenbury

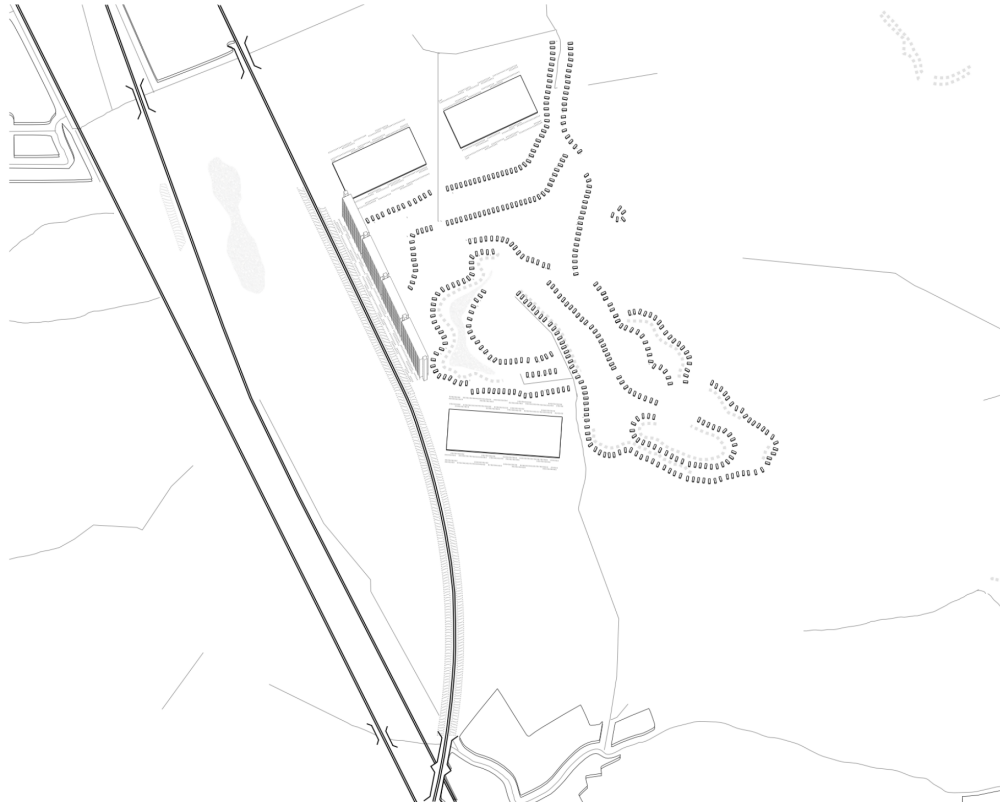

Axonometric of Annesley/Newstead faculty area, a mixed housing development

Diagrammatic comparison of transfer areas

Hucknall
 rail/site – aerial transportor
 road/rail – portal crane
 road/site – mobile cranes and fork-lift vehicles
 air/site – mobile cranes and fork-lift vehicles

Clipstone Colliery
 road/site – portal crane
 road/rail – portal crane
 road/site – lifts, mobile cranes and fork-lift vehicles
 road/site – personnel travelator

Tversal
 road/site – portal crane and movable jib crane
 rail/rail – portal crane and movable jib crane
 road/rail – portal crane and movable jib crane

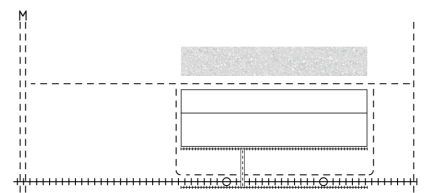
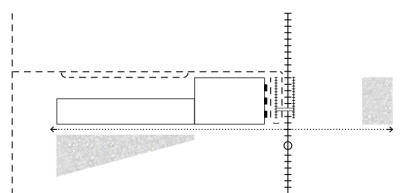
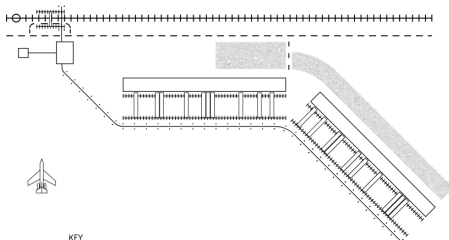

- KEY
- rail route and alighting point
- road
- railway
- ←----- travelator
- portal crane
- aerial transportor
- parking

Space provision

	Variable	Fixed	Living
Hucknall	210.704ha	3.345ha	0.114ha
Clipstone Colliery	289.967ha	2.676ha	
Tversal	441.475ha	4.162ha	1.099ha